

J_B LABARRE

CRÉÉ LE
2023-06-21

Surface totale 78.92 m ²	Étages 1	Pièces 8	Salles de bain 1.1
---	--------------------	--------------------	------------------------------

▼ 2e étage

SURFACE TOTALE : 78.92 m² • SURFACE HABITABLE : 70.74 m² • PIÈCES : 8

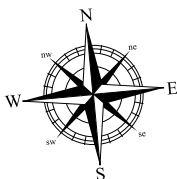
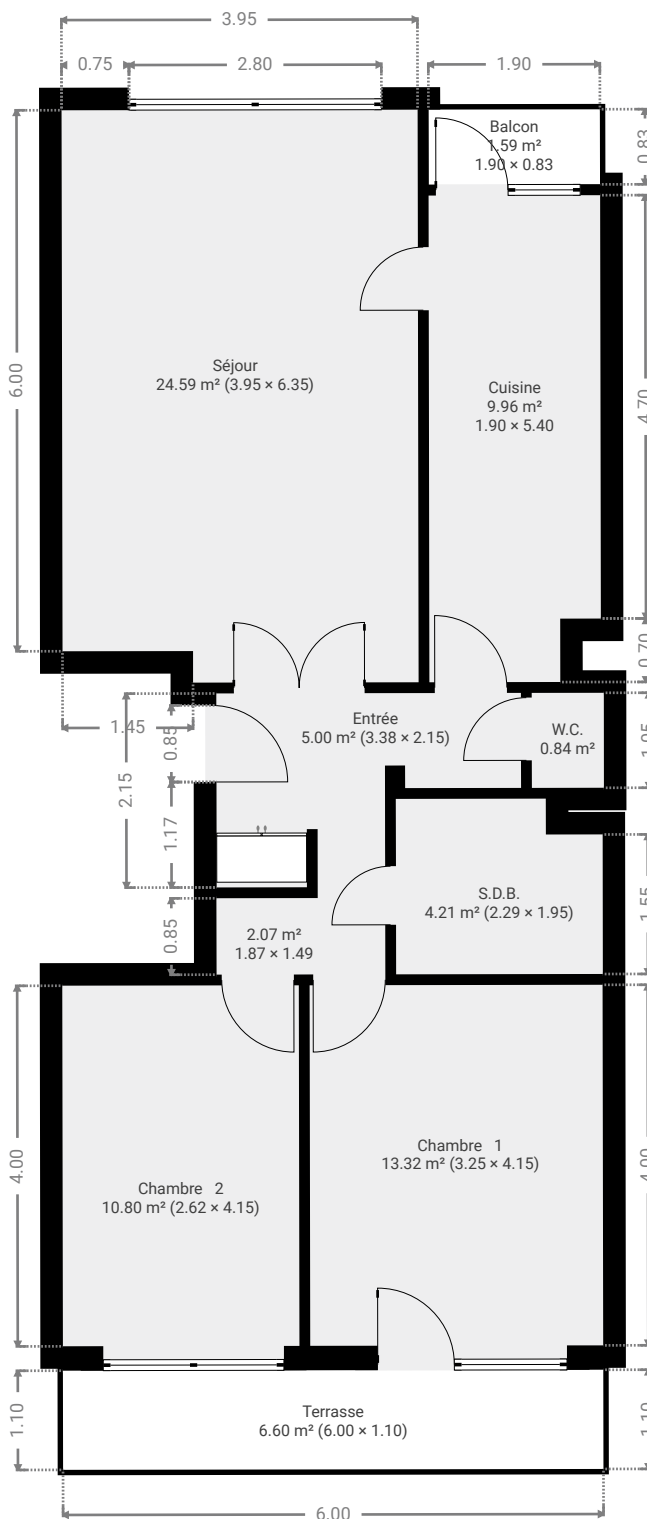

▼ 2e étage

LARGEUR : 1.87 m • LONGUEUR : 1.49 m
SURFACE : 2.07 m² • PÉRIMÈTRE : 6.73 m

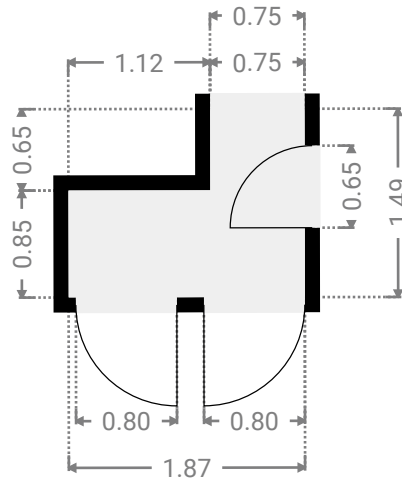
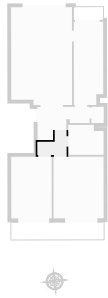

▼ Chambre 1
2e étage

LARGEUR : 3.25 m • LONGUEUR : 4.15 m
SURFACE : 13.32 m² • PÉRIMÈTRE : 14.80 m

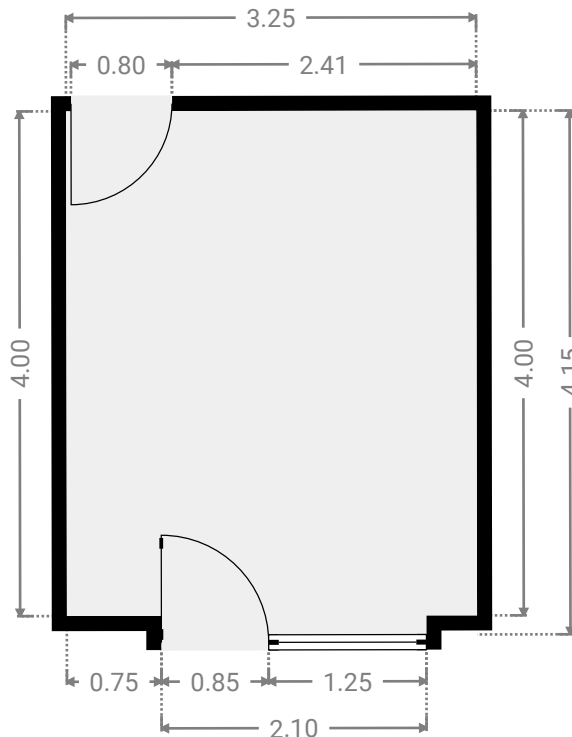
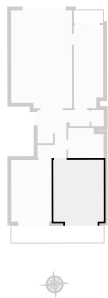

▼ Chambre 2 2e étage

LARGEUR : 2.62 m • LONGUEUR : 4.15 m
SURFACE : 10.80 m² • PÉRIMÈTRE : 13.55 m

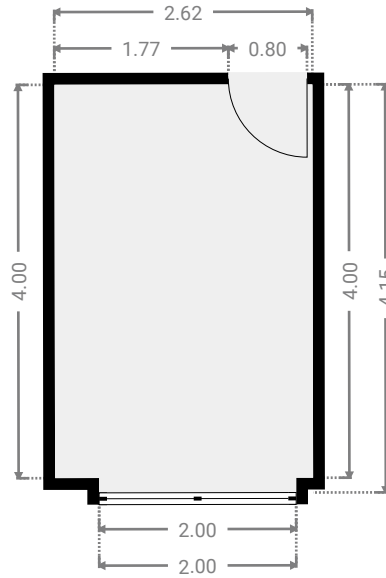
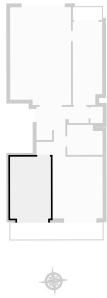

▼ Cuisine 2e étage

LARGEUR : 1.90 m • LONGUEUR : 5.40 m
SURFACE : 9.96 m² • PÉRIMÈTRE : 14.61 m

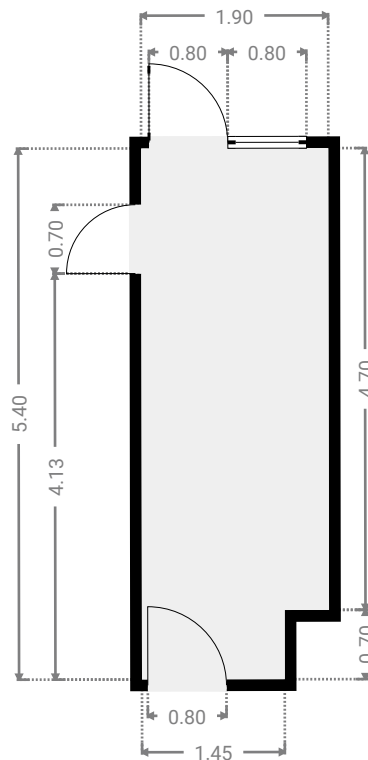
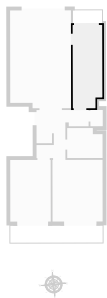

▼ **Balcon**
2e étage

LARGEUR : 1.90 m • LONGUEUR : 0.83 m
SURFACE : 1.59 m² • PÉRIMÈTRE : 5.47 m

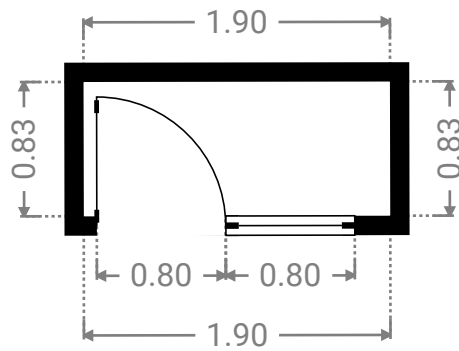
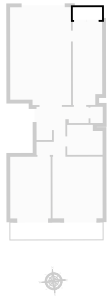

▼ **Entrée**
2e étage

LARGEUR : 3.38 m • LONGUEUR : 2.15 m
SURFACE : 5.00 m² • PÉRIMÈTRE : 11.56 m

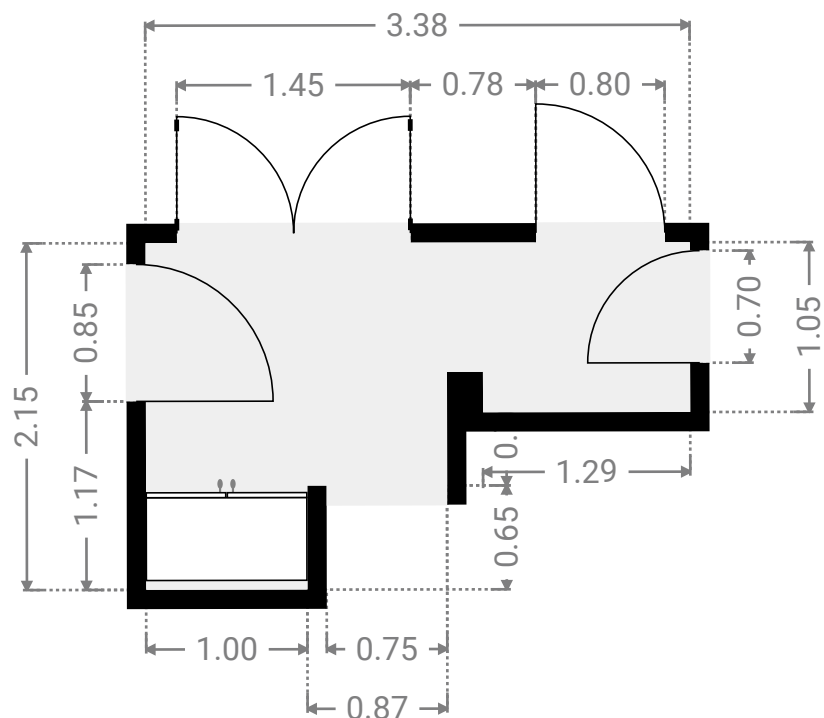
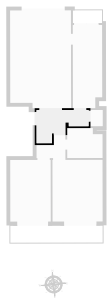

▼ S.D.B. 2e étage

LARGEUR : 2.29 m • LONGUEUR : 1.95 m
SURFACE : 4.21 m² • PÉRIMÈTRE : 8.48 m

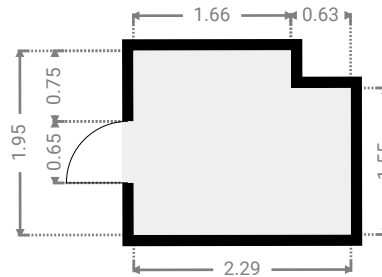
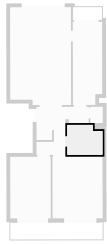

▼ Séjour 2e étage

LARGEUR : 3.95 m • LONGUEUR : 6.35 m
SURFACE : 24.59 m² • PÉRIMÈTRE : 20.61 m

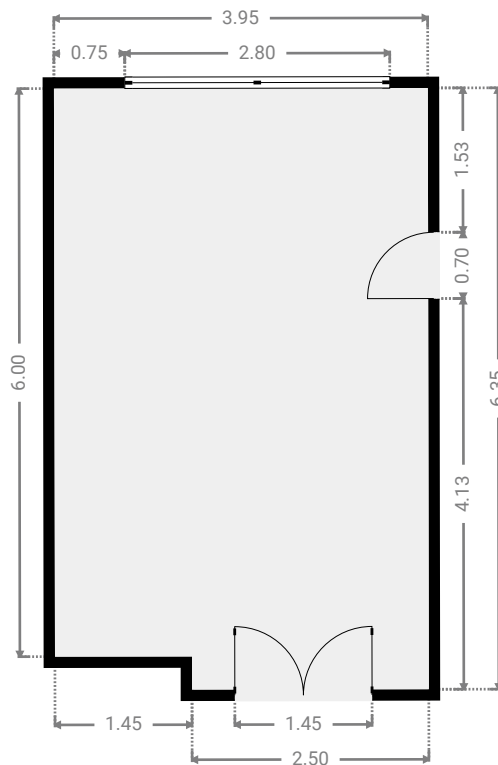
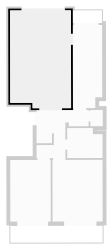

▼ Terrasse 2e étage

LARGEUR : 6.00 m • LONGUEUR : 1.10 m
SURFACE : 6.60 m² • PÉRIMÈTRE : 14.19 m

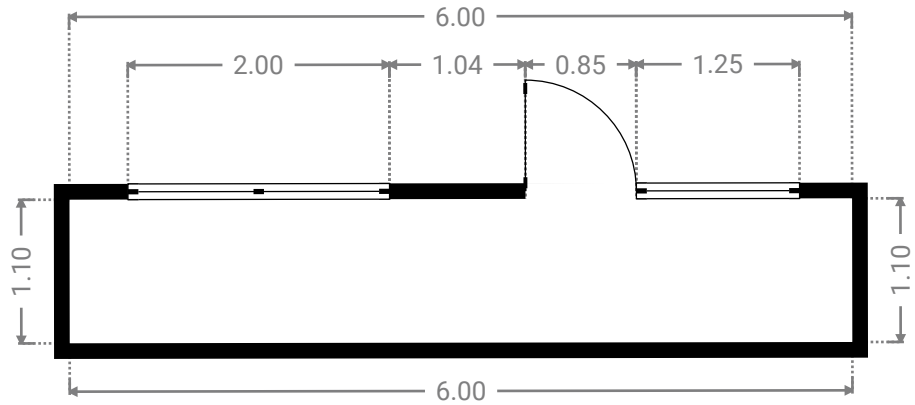

▼ W.C. 2e étage

LARGEUR : 0.80 m • LONGUEUR : 1.05 m
SURFACE : 0.84 m² • PÉRIMÈTRE : 3.71 m

